

MicroNet BACnet Plant Controller



SPECIFICATIONS

HARDWARE

Dimensions

10-15/16 H x 8-3/8 W x 2-9/32 D in. (278 x 213 x 58 mm).

Enclosure

Optional rugged sheet metal enclosure conforms to NEMA-1.

Mounting

Panel mount.

Power Supply Input

20.4 to 30 Vac, 50/60 Hz.

Power Consumption

50 VA at 24 Vac.

AGENCY LISTINGS

US

FCC Part 15, Class A.

UL 916, File #E71385 Category PAZX

UL 864, Category UUKL, File #S5381 Smoke-Control Equipment

Canadian

UL Listed to Canadian Safety Standards (CAN/CSA 22.2).

CUL Listed to Standards

ULC/ORD-C100-92 (Smoke Control System Equipment) and CAN-ULC-S527 (Control Units for Fire Alarm Systems)

Australian

Meets requirements to bear the C-Tick Mark.

European Community

EMC Directive 89/336/EEC
EN61326

MicroNet BACnet Plant Controller MNB-1000

The TAC I/A Series™ MicroNet™ BACnet™ Plant Controller is an interoperable controller with native BACnet/IP, BACnet Ethernet, and MS/TP communications support and routing functionality between physical networks. The controller features: Sensor Link (S-Link) support; remote I/O support; LED status and output indication; two Ethernet ports; screw terminal blocks; and a panel-mount subbase with a removable electronics module.

The Plant Controller's sequence of operation and BACnet image are fully programmable using WorkPlace Tech Tool, and can be applied to a wide range of mechanical equipment. Typical applications include central station air handlers, VAV air handlers, and cooling towers.

The MicroNet BACnet Plant Controller can function either in a standalone mode or as part of a BACnet building automation system (BAS) network.

AMBIENT LIMITS

Operating Temperature

-40 to 140 °F (-40 to 60 °C).

Shipping and Storage Temperature

-40 to 160 °F (-40 to 71 °C).

Humidity

5 to 95% non-condensing.

WIRING TERMINALS

Remote I/O (IO+, IO-, SLD)

Removable screw terminals; single AWG #14 (2.08 mm²) wire or up to two AWG #18 (0.823 mm²) or smaller wires.

MS/TP (MS+, MS-, SLD)

Removable screw terminals; single AWG #14 (2.08 mm²) wire or up to two AWG #18 (0.823 mm²) or smaller wires.

I/O Points

Fixed screw terminals; single AWG #14 (2.08 mm²) wire or up to two AWG #18 (0.823 mm²) or smaller wires.

Power

Removable screw terminals; up to two AWG #14 (2.08 mm²) or smaller wires.

Continued on next page.

Continued from first page.

INPUTS FROM MN-SX MICRONET SENSOR

Space Temperature
32 to 122 °F (0 to 50 °C).

Space Humidity
5 to 95% RH, non-condensing.

Local Setpoint
Adjustable within limits set by application programming tool.

Fan Operation and Speed Mode
On/off, speed (low/medium/high), or auto.

System Mode
Heat, cool, off, or auto.

Emergency Heat
Enable or disable.

UNIVERSAL INPUTS (12)

Universal Input characteristics are software-configured to respond to one of the following input types:

10k ohm Thermistor with 11k ohm Shunt Resistor
Sensor operating range -40 to 250 °F (-40 to 121 °C), model TSMN-57011-850, TS-5700-850 series, or equivalent.

1k ohm Balco
-40 to 250 °F (-40 to 121 °C), model TSMN-81011, TS-8000 series, or equivalent.

1k ohm Platinum
-40 to 240 °F (-40 to 116 °C), model TSMN-58011, TS-5800 series, or equivalent.

1k ohm Resistive
0 to 1500 ohms.

10k ohm Resistive
0 to 10.5k ohms.

Analog Voltage
Range 0 to 5 Vdc.

Analog Current
Range 0 to 20 mA; requires external 250 ohm shunt resistor (AD-8969-202).

Digital
Dry switched contact; detection of closed switch requires less than 300 ohms resistance; detection of open switch requires more than 2.5k ohms.

DIGITAL INPUTS (4)

MODEL

Part Number	Inputs and Outputs ^a			
	UI	DI	UO	DO (Triac)
MNB-1000	12	4	8	8

a. The I/O point count can be greatly expanded with the addition of one to eight Remote I/O Modules, each of which adds 15 I/O points. Refer to the MNB-1000-15 Remote I/O Module sales data sheet, F-27487.

Dry Switched Contact

Detection of closed switch requires less than 300 ohms resistance; detection of open switch requires more than 2.5k ohms.

FAST PULSE INPUT (DIGITAL INPUT ONLY)

Minimum Rate
1 pulse per 4 minutes.

Maximum Rate
10 pulses per second.

DIGITAL OUTPUTS – TRIAC (8)

12 VA at 24 Vac, 50/60 Hz, each output individually isolated.

UNIVERSAL OUTPUTS (8)

0 to 20 mA
Output load from 80 to 550 ohms.

0 to 10 V
With external 500 ohms, 1/2 W, 1% resistor.

Capable of Driving Functional Devices RIBU1C Relay
UO configured for 0 to 20 mAdc, no external resistor.

20 VDC OUTPUT
20 Vdc ±10% at 100 mA.

OPTIONS

MNB-1000-ENC
Wall-mount enclosure

MNB-BASE-1000
Controller Base assembly only

MNB-CNTRLR-1000
Controller Cover assembly only

MNB-15
Remote I/O Module

S-Link Sensors
Temperature and humidity Wall Sensors with digital communication

TSMN Series
Room Temperature Sensors

FEATURES

- The MicroNet BACnet Plant Controller's sequence of operation and BACnet image are fully programmable using WorkPlace Tech Tool.
- Capability to function in standalone mode or as part of a TAC I/A Series building automation network.
- Removable electronics module mates with panel-mounted subbase.
- Removable terminals for power and communications, to facilitate commissioning.
- Integral MS/TP jack for direct connection of PC with WorkPlace Tech Tool Suite.
- Optional rugged, NEMA 1 sheet metal enclosure.
- MS/TP DIP switch addressable.
- Service pin button for BACnet "I am" message broadcast.
- Isolated EIA-485 (formerly RS-485) transceiver for MS/TP communications.
- MS/TP baud rate selection from 9.6 up to 76.8 kbaud.
- LED indication of MS/TP and Ethernet IP communication activity, controller status, DO state, and UO state.
- Application-programmable LED provides on/off indication of a user-defined application parameter.
- Firmware upgradeable over the network.
- 72 hour, battery-backed real time clock.
- BBMD, remote connectivity across subnets.
- Support for Remote I/O Modules and S-Link Sensor.
- IP/Ethernet bridge.
- BACnet router functionality.

COMMUNICATIONS

BACnet Networks

The MicroNet BACnet Plant Controller incorporates a fully functional BACnet router between its 3 fully configurable communications ports.

MS/TP

Isolated EIA-485 (formerly RS-485) transceiver, providing support for up to 128 MS/TP devices communicating at 9.6 up to 76.8 kbaud, using standard MS/TP wiring methods.

Ethernet/IP

Dual 10/100 Ethernet ports with modular RJ-45 jacks. Both ports are set to be an Ethernet Bridge, saving on network wiring.

BACnet Ethernet

Standard BACnet Ethernet communications.

BACnet/IP

Communications choices are Standard BACnet/IP, BBMD, or Foreign Device.

S-Link

The Sensor Link (S-Link) communications wiring provides power and a communication interface for one MN-Sx TAC I/A Series MicroNet sensor. The various MN-Sx sensors can provide room temperature, room humidity, setpoint adjustment, and occupancy override. This connection uses two-wire, unshielded cable and is not polarity sensitive. Maximum S-Link bus length is 200 ft (61 m).

Remote I/O

The remote I/O communications wiring provides an interface for one to eight optional MNB-1000-15 Remote I/O Modules, which can be used to expand upon the Plant Controller's onboard I/O.



BACnet is a registered trademark of ASHRAE. ASHRAE does not endorse, approve, or test products for compliance with ASHRAE standards. Compliance of listed products to the requirements of ASHRAE Standard 135 is the responsibility of BACnet International (BI). BTL is a registered trademark of BI.

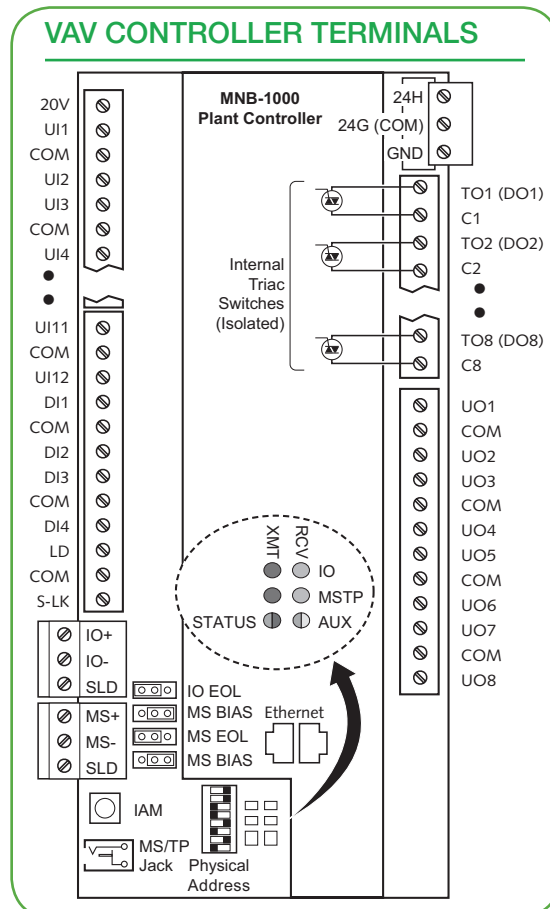

TAC I/A SERIES BACNET TOPOLOGY

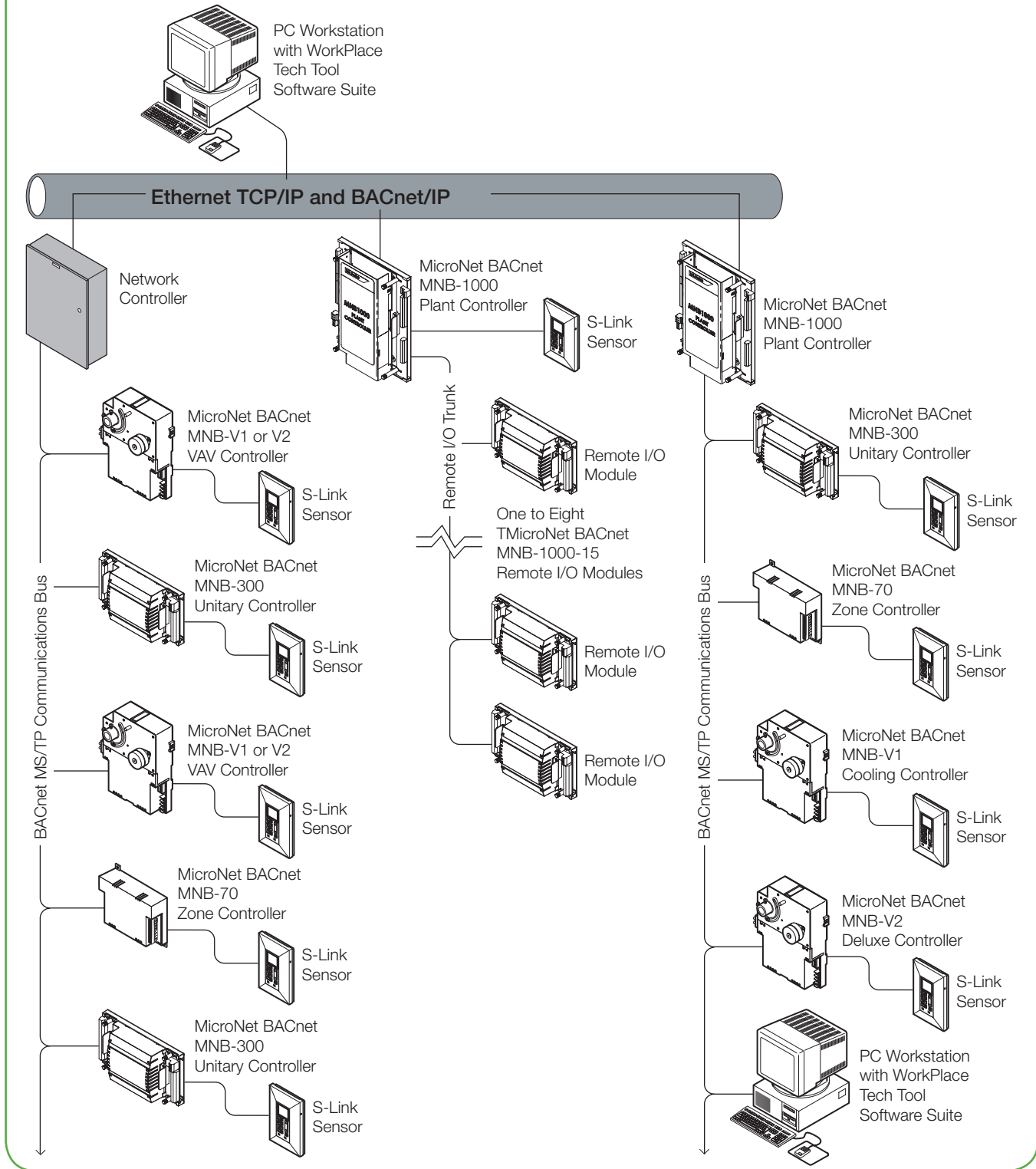

On October 1st, 2009, TAC became the Buildings Business of its parent company Schneider Electric. This document reflects the visual identity of Schneider Electric, however there remains references to TAC as a corporate brand in the body copy. As each document is updated, the body copy will be changed to reflect appropriate corporate brand changes. All brand names, trademarks and registered trademarks are the property of their respective owners. Information contained within this document is subject to change without notice. All rights reserved.