

# MicroNet



## SPECIFICATIONS

### HARDWARE

#### Dimensions

3-5/8 H x 5 W x 1-19/32 D in  
(92 x 127 x 41 mm).

#### Enclosure

Conforms to NEMA-1. Meets UL 94-5VA flammability ratings for plenum application use.

#### Mounting

Panel mount.

#### Power Supply Input

20.4 to 30 Vac, 50/60 Hz.

#### Power Consumption

15 VA at 24 Vac plus DO loads.

### AGENCY LISTINGS

#### US

UL 916, File #E71385 Category PAZX FCC Part 15, Class A.

#### Canadian

UL Listed to Canadian Safety Standards (CAN/CSA 22.2).

#### Australian

Meets requirements to bear the C-Tick Mark.

#### BTL Listing

B-ASC

#### European Community

EMC Directive 89/336/EEC  
EN61326

### BACnet Zone Controller

The TAC I/A Series® MicroNet BACnet Zone Controller is an interoperable controller with native BACnet MS/TP communications support. The controller features: three universal inputs; three digital (Triac) outputs; one universal output; Sensor Link (S-Link) support; LED status indication; and an “I-Am” button.

When programmed using WorkPlace Tech Tool, the Zone Controller provides a wide range of control strategies for applications such as unit heaters, cabinet heaters, fan coil units, small unit ventilators, heat pumps, and single/dual loop control strategies.

The MicroNet BACnet Zone Controller can function either in a standalone mode or as part of a BACnet building automation system (BAS) network.

### AMBIENT LIMITS

#### Operating Temperature

32 to 131 °F (0 to 55 °C).

#### Shipping and Storage Temperature

-40 to 160 °F (-40 to 71 °C).

#### Humidity

5 to 95% non-condensing.

### WIRING TERMINALS

#### Fixed Screw terminals

single AWG #14 (2.08 mm<sup>2</sup>) wire or up to two AWG #18 (0.823 mm<sup>2</sup>) or smaller wires.

### INPUTS FROM MN-SX MICRONET™ SENSOR

#### Space Temperature

32 to 122 °F (0 to 50 °C).

#### Space Humidity

5 to 95% RH, non-condensing.

#### Local Setpoint

Adjustable within limits set by application programming tool.

#### Override Pushbutton

For standalone occupancy control or occupancy override.

*Specifications continued on next page.*

Specifications continued from first page.

**Fan Operation and Speed Mode**

On/off, speed (low/medium/high), or auto.

**System Mode**

Heat, cool, off, or auto.

**Emergency Heat**

Enable or disable.

**UNIVERSAL INPUTS (3)**

Universal Input characteristics are software-configured to respond to one of the following input types:

**10 k ohm Thermistor with 11 k ohm**

**Shunt Resistor**

Sensor operating range -40 to 250 °F (-40 to 121 °C), TAC model TSMN-57011-850, TS-5700-850 series, or equivalent.

**1 k ohm Balco**

-40 to 250 °F (-40 to 121 °C), TAC model TSMN-81011, TS-8000 series, or equivalent.

**1 k ohm Platinum**

-40 to 240 °F (-40 to 116 °C), TAC model TSMN-58011, TS-5800 series, or equivalent.

**1 k ohm Resistive**

0 to 1500 ohms.

**10 k ohm Resistive**

0 to 10.5 k ohms.

**Analog Voltage**

Range 0 to 5 Vdc.

**Analog Current**

Range 0 to 20 mA, requires external 250 ohm shunt resistor (AD-8969-202).

**Digital**

Dry switched contact; detection of closed switch requires less than 300 ohms resistance; detection of open switch requires more than 2.5 k ohms.

**Standard Pulse Input**

Minimum Rate  
1 pulse per 4 minutes.

**Maximum Rate**

1 pulse per second.

**DIGITAL OUTPUTS – TRIAC (3)**

**DO1 plus DO2 Rating**

24 VA total at 24 Vac, 50/60 Hz, high side switching.

**DO3 Rating**

12 VA at 24 Vac, 50/60 Hz, high side switching

**UNIVERSAL OUTPUT (1)**

**0 to 20 mA**

Output load from 80 to 550 ohms.

**0 to 10 V**

With external 500 ohms, 1/2 W, 1% resistor.

**Capable of Driving Functional Devices**

**RIBUI1C Relay**

UO configured for 0 to 20 mAdc, no external resistor.

**MODEL**

Model	Inputs and Outputs		
	UI	UO	DO (Triac)
MNB-70	3	1	3

**OPTIONS**

MNA-FLOd-1	TAC MicroNet enclosure, used if wiring to flexible conduit is required
S-Link Sensors	Temperature and humidity wall sensors with digital communication
TSMN Series	Room temperature sensors

## FEATURES

- The MicroNet BACnet Zone Controller's sequence of operation and BACnet image are fully programmable using WorkPlace Tech Tool. The controller can be applied to all common zone HVAC applications.
- Capability to function in standalone mode or as part of a BACnet building automation network.
- Integral MS/TP jack for direct connection of PC with WorkPlace Tech Tool.
- DIP switch addressable.
- Service pin button for BACnet "I am" message broadcast.
- Isolated EIA-485 transceiver for MS/TP communications.
- MS/TP baud rate selection from 9.6 up to 76.8 kbaud.
- LED indication of MS/TP communication activity and controller status.
- Firmware upgradeable over the network.

## ZONE CONTROLLER TERMINALS

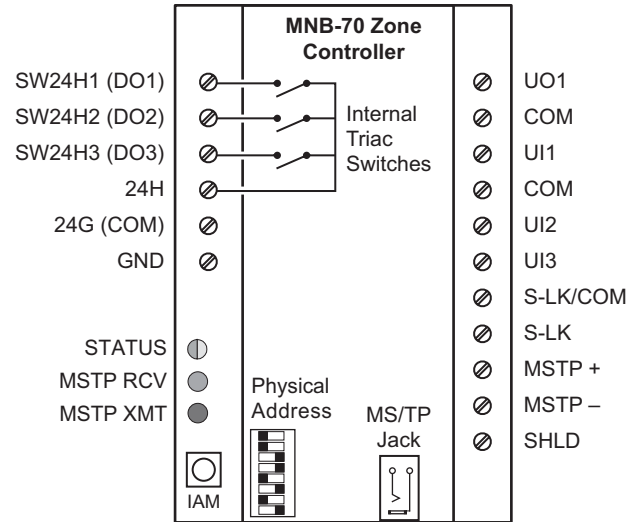

## COMMUNICATIONS

### BACnet Networks

The MicroNet BACnet Zone Controller incorporates an isolated EIA-485 transceiver for BACnet MS/TP communications at 9.6 up to 76.8 kbaud using standard MS/TP wiring methods. Up to 128 TAC MicroNet BACnet controllers can be connected to an MS/TP sub-net without repeaters.

### S-Link

The Sensor Link (S-Link) communications wiring provides power and a communication interface for one MN-Sx TAC I/A Series MicroNet sensor. The various MN-Sx sensors can provide room temperature, room humidity, setpoint adjustment, and occupancy override. This connection uses two-wire, unshielded cable and is not polarity sensitive. Maximum S-Link bus length is 200 ft (61 m).

## BACNET COMPLIANCE

BACnet Application Specific Controller (B-ASC).



BACnet is a registered trademark of ASHRAE. ASHRAE does not endorse, approve, or test products for compliance with ASHRAE standards. Compliance of listed products to the requirements of ASHRAE Standard 135 is the responsibility of BACnet International (BI). BTL is a registered trademark of BI.

## ARCHITECTURE

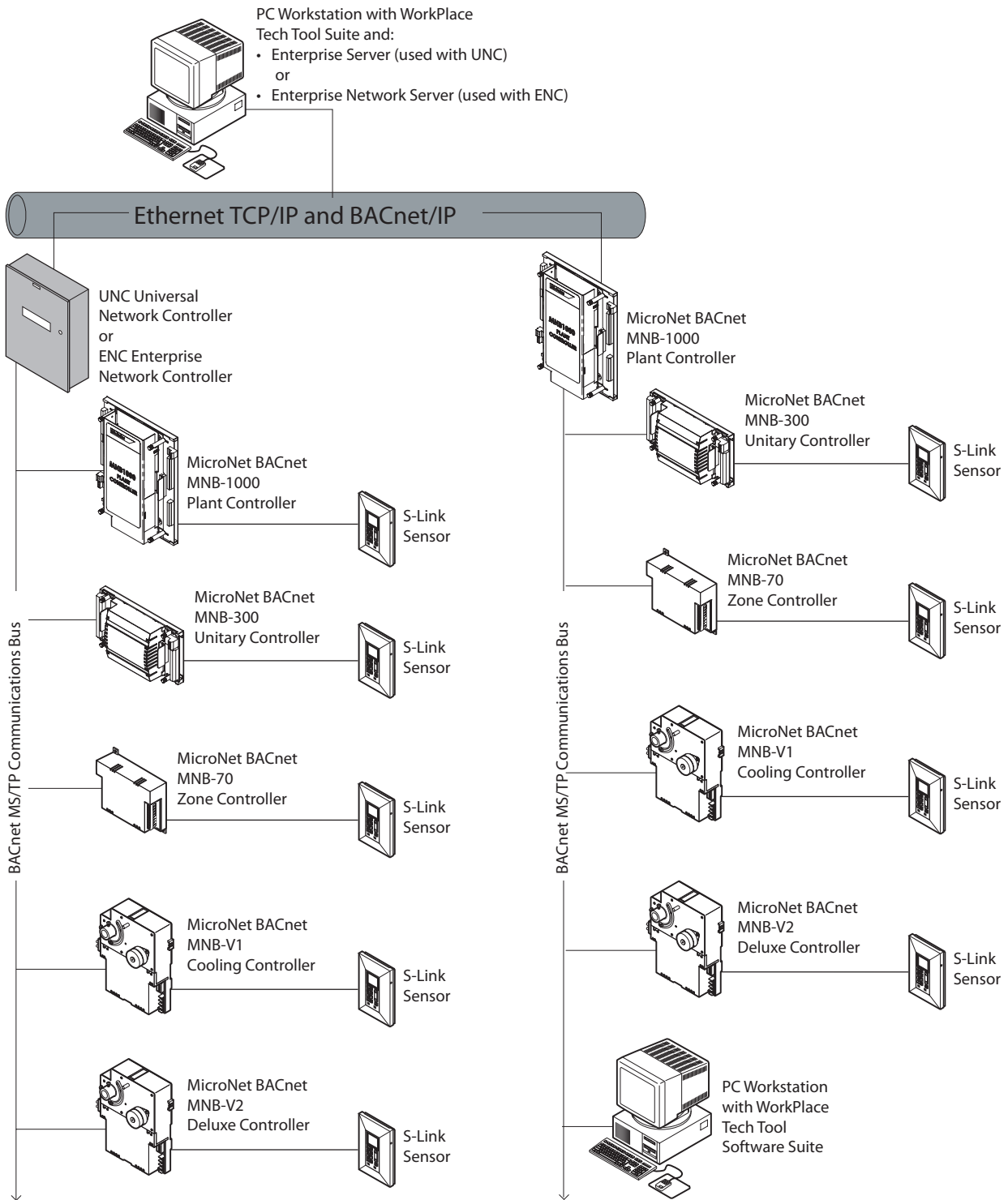

On October 1st, 2009, TAC became the Buildings Business of its parent company Schneider Electric. This document reflects the visual identity of Schneider Electric, however there remains references to TAC as a corporate brand in the body copy. As each document is updated, the body copy will be changed to reflect appropriate corporate brand changes.

All brand names, trademarks and registered trademarks are the property of their respective owners. Information contained within this document is subject to change without notice.

**Schneider Electric** 1354 Clifford Avenue, P.O. Box 2940, Loves Park, IL 61132-2940, USA 1-888-444-1311 [www.schneider-electric.com/buildings](http://www.schneider-electric.com/buildings)